

**Annual Progress Report**  
**(September 2001 – August 2002)**

**Development of a Mechanistic Understanding of High-Temperature Deformation of  
Alloy EP-823 for Transmutation Applications**  
**AAA Task-10**

**Principal Investigator**  
**Ajit K. Roy, Ph.D.**

**Co-Principal Investigator**  
**Brendan J. O'Toole, Ph.D.**

**Investigators**  
**Martin Lewis**  
**Mark Jones**  
**John Motaka**

**University of Nevada Las Vegas**

**September 30, 2002**

# Development of a Mechanistic Understanding of High-Temperature Deformation of Alloy EP-823 for Transmutation Applications

## Introduction

The purpose of this project is to evaluate the elevated temperature tensile properties of Alloy EP-823, a leading target material for accelerator-driven waste transmutation applications. This alloy has been proven to be an excellent structural material to contain the lead-bismuth-eutectic (LBE) nuclear coolant needed for fast spectrum operations. Very little data exist in the open literature on the tensile properties of this alloy. The test material will be thermally treated prior to the evaluation of its tensile properties at temperatures relevant to the transmutation applications. The deformation characteristics of tensile specimens, upon completion of testing, will be evaluated by surface analytical techniques using scanning electron microscopy (SEM) and transmission electron microscopy (TEM). The overall results will lead to the development of a mechanistic understanding of the elevated-temperature deformation processes in this alloy as a function of thermal treatment. The resultant data may also provide guidance in developing future target materials possessing the improved metallurgical properties, and enhanced LBE corrosion resistance.

## Personnel

The current project participants are listed below.

Principal Investigator (PI): Dr. Ajit K. Roy

Co-PI: Dr. Brendan J. O'Toole  
Department of Mechanical Engineering, UNLV  
Roy: Phone: (702) 895-1463 email: [aroy@unlv.edu](mailto:aroy@unlv.edu)  
O'Toole: Phone: (702) 895-3885 email: [bj@me.unlv.edu](mailto:bj@me.unlv.edu)

Investigators (UNLV): Mr. Martin Lewis, M.S. Student, Department of Mechanical Engineering  
Mr. Mark Jones, M.S. Student, Department of Mechanical Engineering  
Mr. John Motaka, B.S. Student, Department of Mechanical Engineering  
Lewis: Phone: (702) 295-4591 email: [Martin.Lewis@ymp.gov](mailto:Martin.Lewis@ymp.gov)  
Jones: Phone: (702) 384-3756 email: [kamproducts@earthlink.com](mailto:kamproducts@earthlink.com)  
Motaka: Phone: (702) 696-0830 email: [primo\\_w@yahoo.com](mailto:primo_w@yahoo.com)

Collaborator (DOE): Dr. Stuart A. Maloy, Los Alamos National Laboratory, New Mexico  
Phone: (505) 667-9784 email: [Maloy@lanl.gov](mailto:Maloy@lanl.gov)

## Accomplishments

Three experimental heats (#2054, 2055 and 2056) of martensitic Alloy EP-823 were melted and processed into round bars at the Timken Research Laboratory (TRL), Canton, Ohio. One heat (#2054) of this material was heat treated at TRL. The sectioned bars were austenitized at 1850<sup>0</sup>F for one hour, followed by an oil-quench. These oil-quenched bars were subsequently tempered at 1150<sup>0</sup>F for 1.25, 1.75 and 2.25

hours, respectively, followed by air-cooling. These tempered bars were identified as 2054S, 2054T and 2054U, respectively. The measured hardness of these quenched and tempered (QT) materials ranged between  $R_c$  29 and 30. The resultant metallurgical microstructures of these heat-treated materials are yet to be analyzed by optical microscopy. The chemical compositions of all three heats of Alloy EP-823 are shown in Table 1.

Table 1  
Chemical Composition of Alloy EP-823+

Material/Heat No.	Elements (wt %)													
	C	Mn	P	S	Si	Cr	Ni	Mo	Cu	V	W	Cb	B	Ce
Alloy EP-823/2054*	0.16	0.55	0.014	0.004	1.09	11.70	0.66	0.74	0.002	0.30	0.60	0.24	0.009	0.04
Alloy EP-823/2055	0.16	0.57	0.014	0.004	1.14	11.71	0.67	0.74	0.002	0.31	0.58	0.23	0.009	0.04
Alloy EP-823/2056	0.14	0.56	0.013	0.005	1.11	11.68	0.66	0.73	0.002	0.30	0.62	0.22	0.009	0.05

+Melted and Processed at TRL

\*Thermal Treatments Performed:

Austenitized: 1850°F/ 1 hr/ OQ

Tempered: 1150°F/ 1.25 hr/ AC (coded as S)

(In 3 batches) 1150°F/ 1.75 hr/ AC (coded as T)

1150°F/ 2.25 hr/ AC (coded as U)

Key to Abbreviations:

OQ: Oil Quenched

AC: Air Cooled

Cylindrical smooth tensile specimens (4-inch long, 1-inch gage length and 0.25-inch gage diameter) were machined from these heat-treated bars by a qualified vendor. These specimens were machined in such a way that the gage section was parallel to the longitudinal rolling direction. The ambient temperature mechanical properties of tensile specimens, fabricated from heat #2054 using two different tempering times (i.e. Codes S and T), were determined in air by using an existing calibrated Materials Testing System (MTS) machine. The room-temperature tensile data for these materials are shown in Table 2. The stress-strain diagrams of Alloy EP-823 for heat number 2054 under two different heat-treating conditions (S and T) are shown in Figures 1 and 2, respectively.

A high-temperature inert gas chamber with water-cooled jacket for specimen grips has been installed in the existing MTS machine to perform tensile testing of Alloy EP-823 under controlled environmental (nitrogen) condition at ambient and elevated temperatures. An air-cooled extensometer has also been added to this chamber to monitor the displacement of these specimens while being pulled at the ASTM-specified strain rate at different testing temperatures. The test setup is shown in Figures 3a, 3b and 3c.

Table 2

Ambient Temperature Mechanical Properties of Alloy EP-823

Material/Heat No.	Sample ID	YS (ksi)	YS <sub>avg.</sub> (ksi)	UTS (ksi)	UTS <sub>avg.</sub> (ksi)	% El	% RA	Hardness
Alloy EP-823/2054S	S1	111	110.67	130	129.67	19.90	59.28	Rc30
	S2	110		129		20.75	62.19	Rc30
	S3	111		130		22.65	61.52	Rc30
Alloy EP-823/2054T	T4	110	110	131	131.33	21.80	61.29	Rc30
	T5	112		134		20.75	61.56	Rc30
	T6	108		129		20.85	60.70	Rc30

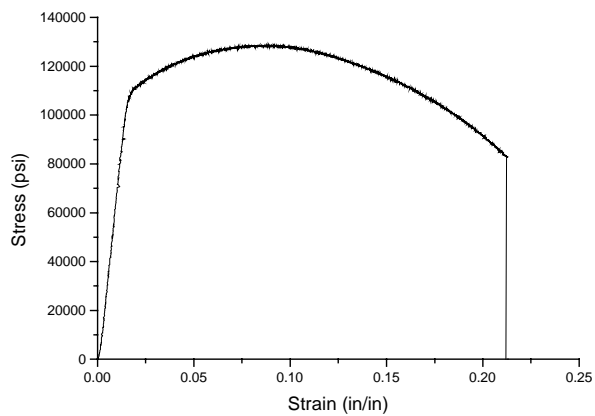

Figure 1. Stress-Strain Plot of Alloy EP-823/2054S

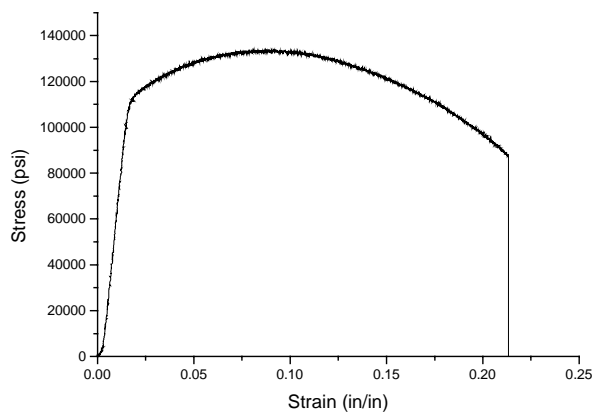

Figure 2. Stress-Strain Plot of Alloy EP-823/2054T

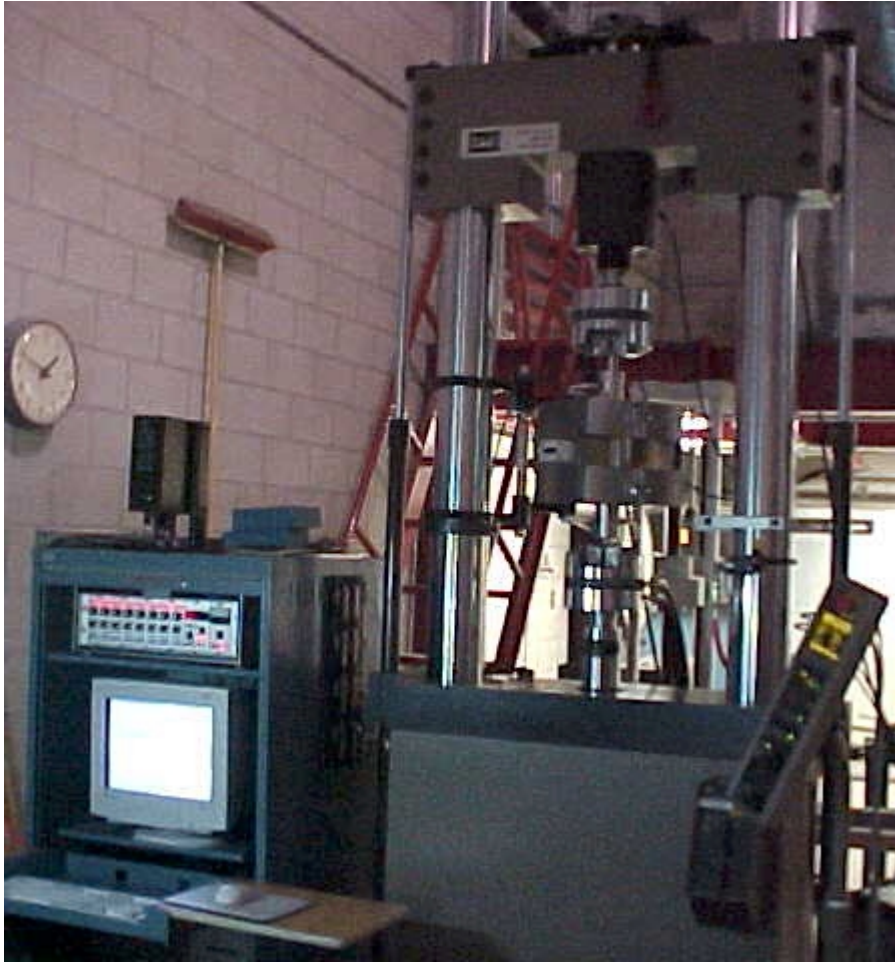

Figure 3a. MTS Test Setup

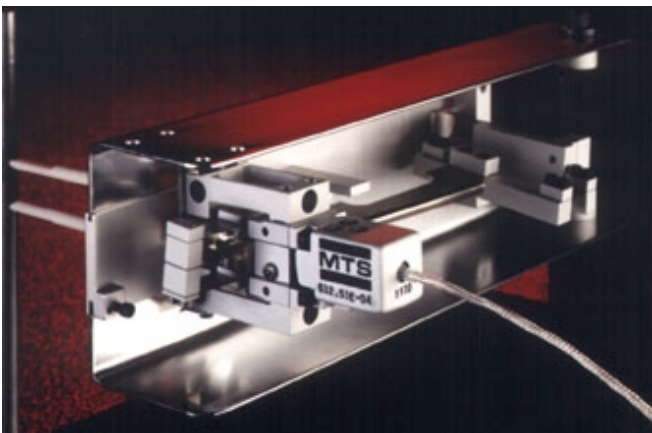

Figure 3b. Extensometer

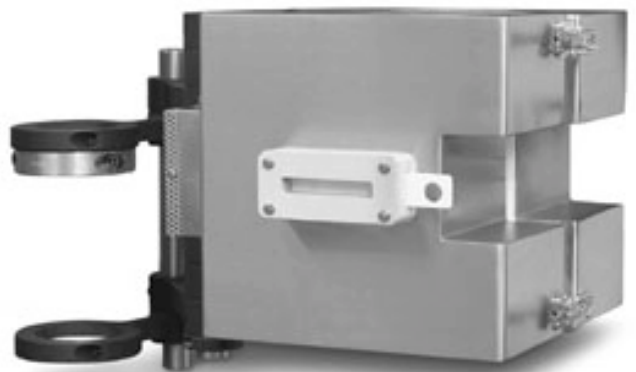

Figure 3c. High-Temperature Chamber

## Work in Progress

The experimental setup to perform high-temperature tensile testing is almost ready except for the fact that a 240-volt electrical outlet is yet to be installed in the vicinity of the MTS unit. Further, a water line has to be installed to cool the specimen grips, thus maintaining an ambient temperature outside the heating chamber. Inter-departmental-requisition (IDR) requests were submitted to the UNLV planning and construction department in July 2002 to have both the electrical and plumbing works done in a timely manner to initiate these elevated temperature testing. However, these tasks are still pending.

A set of adaptor fixtures for use in the furnace has been designed and is being fabricated. The fixtures have pinned connections so we do not have to disconnect the grip cooling lines while installing specimens for testing. Finite element analysis was performed on the fixtures to determine maximum stresses before selecting the appropriate material. Figure 4 shows a sample of the FEA results and Figure 5 shows the entire adaptor assembly.

Upon completion of these infrastructure tasks, tensile testing will be performed at temperatures ranging from ambient to 540°C using ASTM Standard E 8 in the presence of pure nitrogen gas inside the heating chamber. The metallurgical microstructures of broken test specimens will be analyzed by standard metallographic methods (mounting, polishing and etching). SEM will be used to determine the morphology (ductile versus brittle) and the extent of failure in each specimen tested at different temperatures. TEM will be used to characterize the distribution and nature of dislocations and other imperfections, so that the precise deformation mechanisms for Alloy Ep-823 can be established as functions of thermal treatments and testing temperatures.

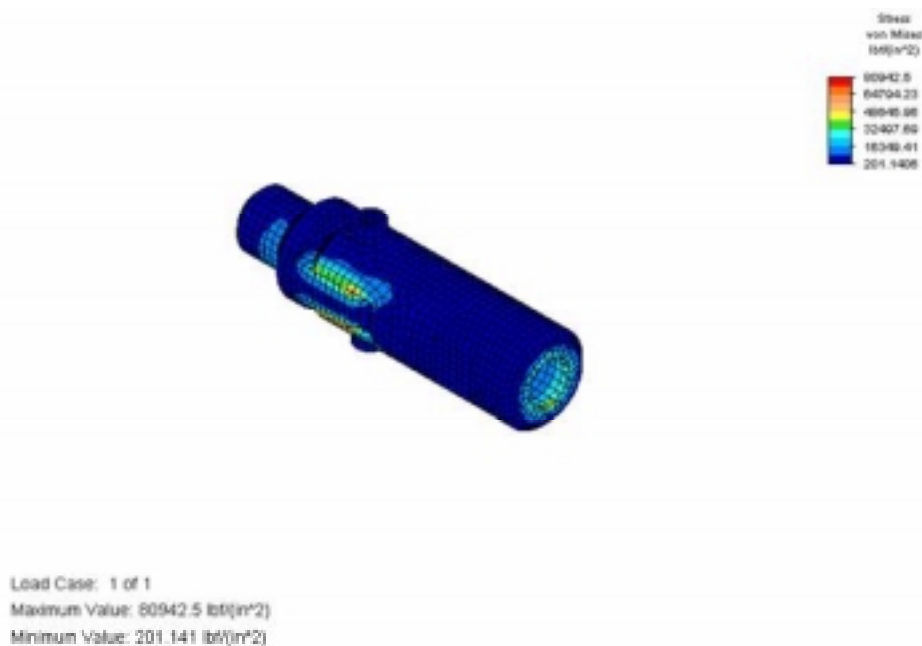

Figure 4: Stress Contour for Part of the Tensile Test Fixture

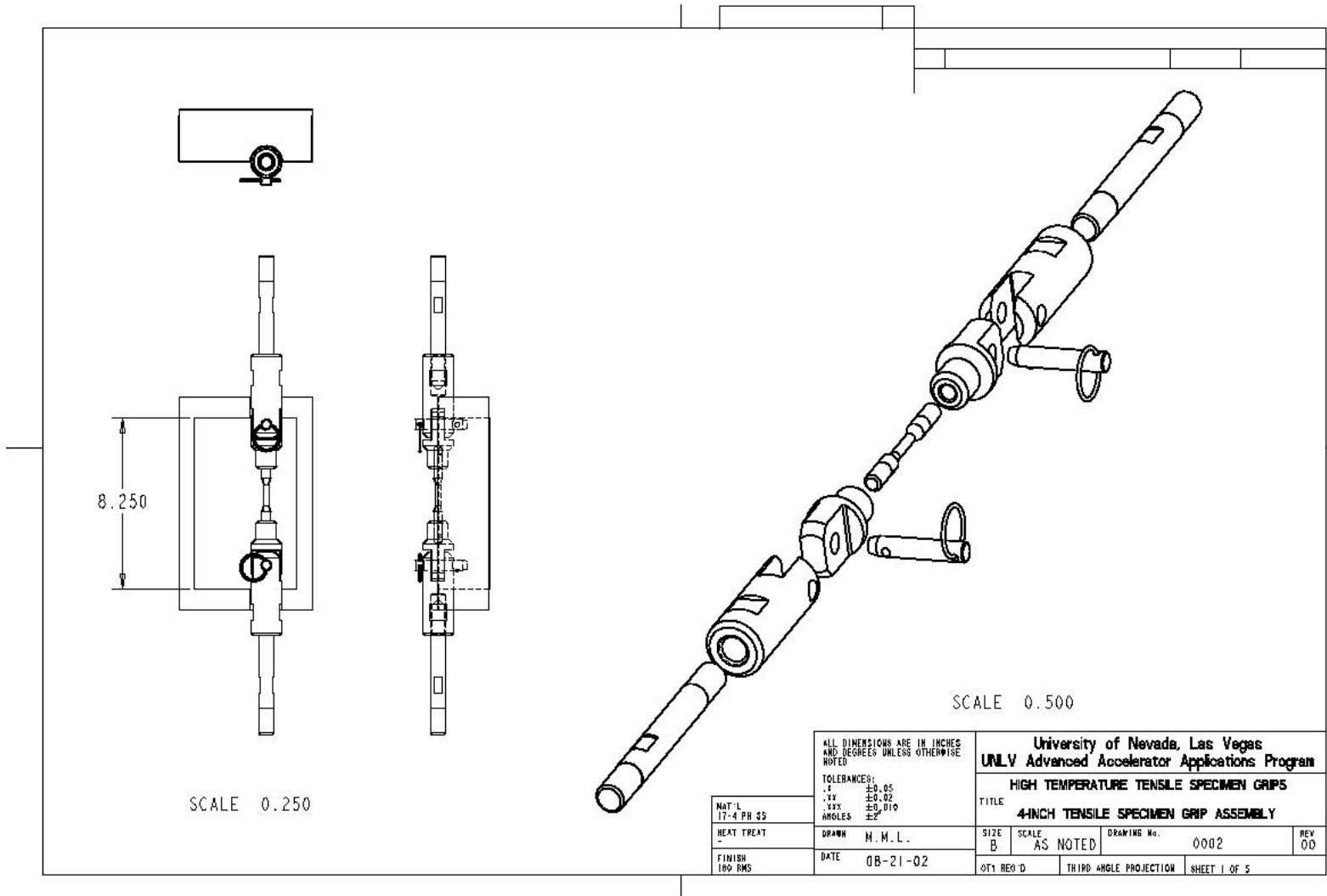

Figure 5: Tensile Fixture For Use in Furnace