

Task 7

Development of Dose Coefficients for Radionuclides Produced in Spallation Targets

P.W. Patton and M.J. Rudin

BACKGROUND

Ensuring the safety of workers at accelerator-driven nuclear facilities is paramount before these systems can be deployed for nuclear transmutation or any other mission. Spallation neutron sources produce as many as 660 rare radionuclides in either the target or blanket during the spallation process. No data exists for many of these radionuclides in the current radiation protection guidelines and standards. This research program seeks to address this problem through generating internal and external dose coefficients (DCs) for these “new” isotopes.

Dose coefficients permit simple determination of radiation dose associated with various exposure scenarios, and ultimately permit radiation safety personnel to assess the health risks to workers in a nuclear facility. Specifically, radiation safety personnel use dose coefficients to determine the radiation dose incurred to a tissue or organ system from a given exposure. These parameters are often expressed in terms of Annual Limits on Intake (ALIs) and Derived Air Concentrations (DACs).

Results from this study will be used to produce ALIs and DACs for these rare radionuclides created by spallation target systems that are not included in Federal Guidance Report (FGR) No. 11. Additionally, DCs developed will augment the

radiological data in Publications 68 and 72 of the International Commission on Radiological Protection (ICRP), contributing to the safe operation of accelerator-driven nuclear systems in the United States and abroad.

RESEARCH ACCOMPLISHMENTS

A Dose Coefficient Working Group was established in 2001 (the first year of the project) to direct and oversee consortium activities. Representatives from the Dose Coefficient Working Group developed and verified a methodology to determine internal and external dose for select radionuclides. The first step involved obtaining radiological data from the ENSDF nuclear physics database developed at Brookhaven National Laboratory. Data collected included decay modes, decay energy levels, and radiation energies and intensities.

The DC working group prioritized a list of radionuclides projected to be released via air emissions or in the inventory of a mercury target following a lengthy irradiation period. Only radionuclides with a half-life greater than one minute were considered. These 81 radionuclides were then categorized into three distinct categories, based on half-life, available information, and other technical factors.

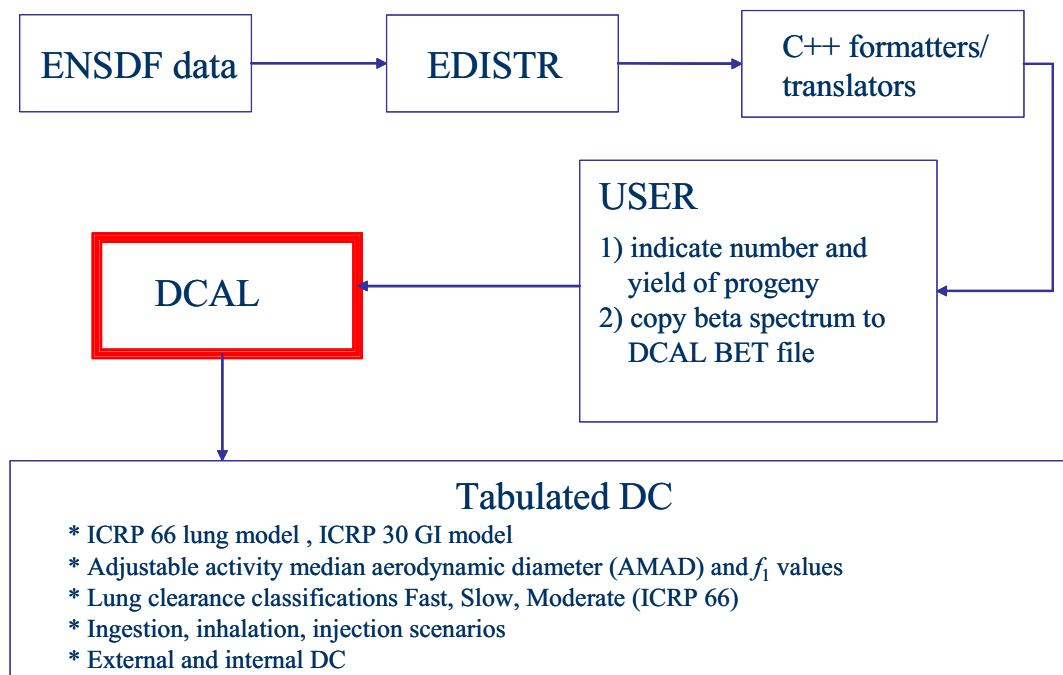

Dose Coefficient Working Group Methodology Flow Sheet. The ENSDF code is used to obtain nuclear physics data. The EDISTR code prepares the data for input into the dose calculation code DCAL.

All Category 2 radionuclides were investigated to determine which database was most current. However, this task was not straight forward and thus both databases were used to calculate all radionuclides that had complete data. Dose coefficients were then generated for the Category 2 radionuclides using both ENSDF and NUBASE. The results were compared and showed good agreement. Metabolic models and data from ICRP publications (30 and 66) were applied in order to use the best technology available and to maintain consistency with current standards. In accordance with FGR No. 11, dose coefficients were evaluated for an adult male with the target tissues of gonads, breast, lung, red marrow, bone surface (endosteum), thyroid, remainder, and total committed effective dose equivalent (this considers total dose incurred to specific organs or tissues with respect to radiation type over a period of 50 years). Following determination of these variables, values of ALIs and DACs were then calculated for each radionuclide.

Efforts to add representatives from other countries to serve as members on the Transmutation Research Program (TRP) DC consortium were completed. Currently, faculty and students from the following academic institutions participate in the consortium: Georgia Institute of Technology, University of Nevada Las Vegas, Idaho State University, Texas A&M University, and Tbilisi State University (in Tbilisi, Republic of Georgia). Los Alamos National Laboratory and Oak Ridge National Laboratory are also represented in the consortium.

FUTURE WORK

Results from this work will be invaluable to individuals and organizations responsible for ensuring the safety of their workers in accelerator facilities, and the national and international radiation safety profession in general.

During the next year of this project, the consortium will devote its time to obtaining nuclear data that permits calculation of dose coefficients for radionuclides in the third category. These calculations prove challenging. Incomplete radiological data characterizes those radionuclides in category three. It is the goal of the consortium to create these rare radionuclides and study them.

HIGHLIGHTS

- ◆ Completion of Dose Coefficient Calculations for Category Two radionuclides resulting from the Spallation process.
- ◆ “Calculation of Dose Coefficients for Radionuclides Produced in Spallation Neutron Sources” presented at the national meeting of the Health Physics Society, San Diego, CA, July 22, 2003.
- ◆ “Evaluation of Nuclear Databases and the Calculation of Dose Coefficients for Radionuclides Produced in a Spallation Neutron Source” presented at the Lake Mead Chapter of the Health Physics Society, Las Vegas, NV, December 9, 2003.
- ◆ Yayun Song completed her M.S. in Health Physics (April 2004), thesis entitled “Investigation and Calculations of Dose Coefficients for Radionuclides Produced in a Spallation Neutron Source Using the ENSDF and NUBASE Nuclear Databases.”

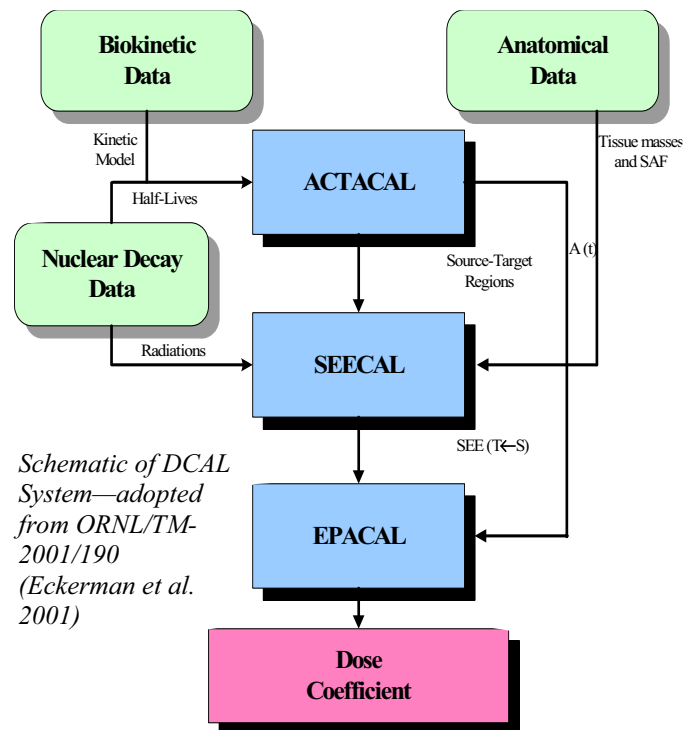

Research Staff

Phillip W. Patton, Principal Investigator, Assistant Professor, Department of Health Physics
 Mark Rudin, Chair, Department of Health Physics

Students

John Shanahan and Yayun Song, Graduate Students, Department of Health Physics
 Laura Mercer, Undergraduate Student, Department of Health Physics

Collaborators

Keith F. Eckerman, Oak Ridge National Laboratory
 Faculty and graduate students from Idaho State University, Georgia Institute of Technology, Texas A&M University, University of Florida, and Tbilisi State University (Tbilisi, Republic of Georgia)